

MaxMotion

Date: 2020-03-10

PERFORMANCE DATA SHEET

Meets or exceeds MEPS (Minimum Efficiency Performance Standards), as described by the US Department of Energy in docket 10CFR431 and Natural Resources Canada's Amendment 14

Catalogue #: **MPRP-154CH**

HP	kW	Voltage	S.F. @ 60Hz	EFF.	P.F.	Frame	Design	L.R. Amps
1.5	1.12	575	1.15	86.7%	0.790	56HC	B	15

60 Hz								
FLA							Code	F.L. RPM
208	230	416	460	480	575	600		
/	/	/	/	/	1.65	/	L	1745

50 Hz								
HP	kW	FLA		S.F. @ 50Hz	Efficiency	P.F.	Code	F.L. RPM
		190	380					
/	-	/	/	/	/	/	/	/

Wgt. Lbs	PH	Duty	Insul. Class	Amb.	Elevation	Temp. Rise° C
31	3	Cont.	F	40°C	1000M (3,300 Ft)	45

% Efficiency		% Power Factor		Torque		Winding Resist. Ω	Safe Cold Start (Secs)
Full Load:	86.7%	Full Load:	0.79	Full Load Ft/Lbs	4.5		
3/4 Load:	86.9%	3/4 Load:	0.71	Locked Rotor %	353		
1/2 Load:	85.0%	1/2 Load:	0.57	Break Down %	436	16.49	12

Rotor Inertia Wk2 Lb-Ft2	Max Load Inertia Wk2 Lb-Ft2	Shaft Material	Frame Material	DE Bracket Type	ODE Bracket Type	Enclosure	NEMA Rating	Lead Wire Size
/	/	Steel	Rolled Steel	Aluminium Alloy		TEFC	IP55	0

Ball Bearings		Grease	Mount Type	Orientation	Paint	Sound Pressure @ 3FT	Sound Power
DE	ODE						
6205	6203	Sealed Bearings	Rigid	Horizontal	Black	61	/

Inverter Duty.	Constant Torque Range	Variable Torque Range	Constant HP RPM
Motor meets MG1 parts 31.4.4.2	10:1	20:1	/

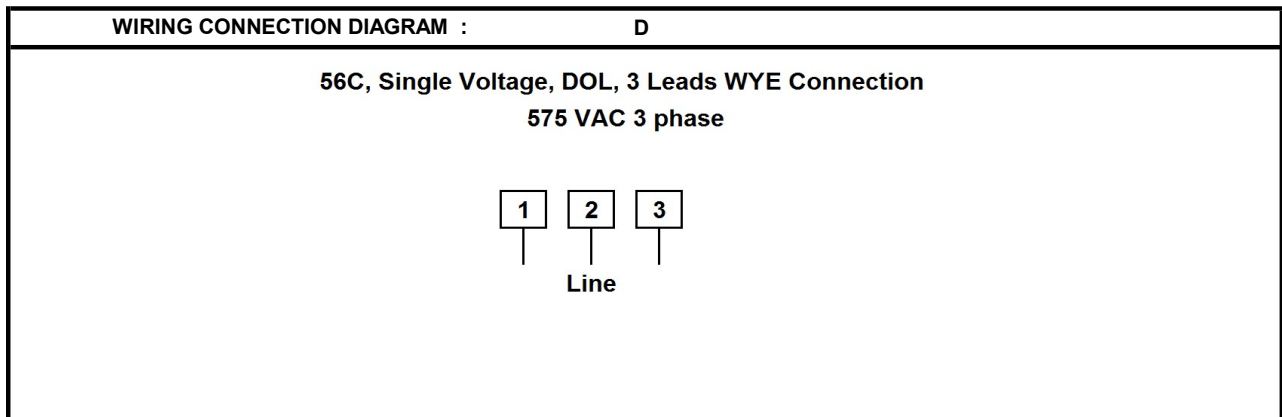

Date: 2020-03-10
 Customer: _____
 Contact: _____
 Submittee: J.C. Lavallée

Catalogue #: **MPRP-154CH**

Meets or exceeds MEPS (Minimum Efficiency Performance Standards), as described by the US Department of Energy in docket 10CFR431 and Natural Resources Canada's Amendment 14

HP	VAC	RPM	Enclosure	Frame	Frequency	Design	Poles	LR Code Letter	Insulation Class	Temp. Rise °C
1.5	575	1745	TEFC	56HC	60	B	4	L	F	45
	0Hz	6Hz	15Hz	30Hz	45Hz	60Hz	75Hz	90Hz	105Hz	120Hz
Amps	1.65	1.65	1.65	1.65	1.65	1.65	1.65	1.65	1.65	1.65
RPM	0	174.5	436.25	872.5	1308.75	1745	2181.25	2617.5	3053.75	3490
Torq ft.lb	3.61	3.61	4.51	4.51	4.51	4.51	3.61	3.01	2.58	2.26
Peak Tq ft.lb	7.18	14.36	14.36	14.36	14.36	14.36	11.49	9.57	8.20	7.18
HP	0	0.1	0.4	0.8	1.1	1.5	1.5	1.5	1.5	1.5
	Locked Rotor	Pull-Up	Breakdown	Rated Load	Idle	Duty	S. F.	Ambient	Elevation	dBA @ 1M
Speed (RPM)	0.0	756	1440	1745	1800	Continuous	1.15	40°C	3,300 ft	61
Current (Amps)	15.0	12.8	8.9	1.7	1.0	VFD Rating: Meets MG1 parts 31.4.4.2				
Torque (ft.-lbs)	15.9	13.5	19.7	4.5	0.0	C.T.	10:1	V.T.	20:1	

Motor Speed Data

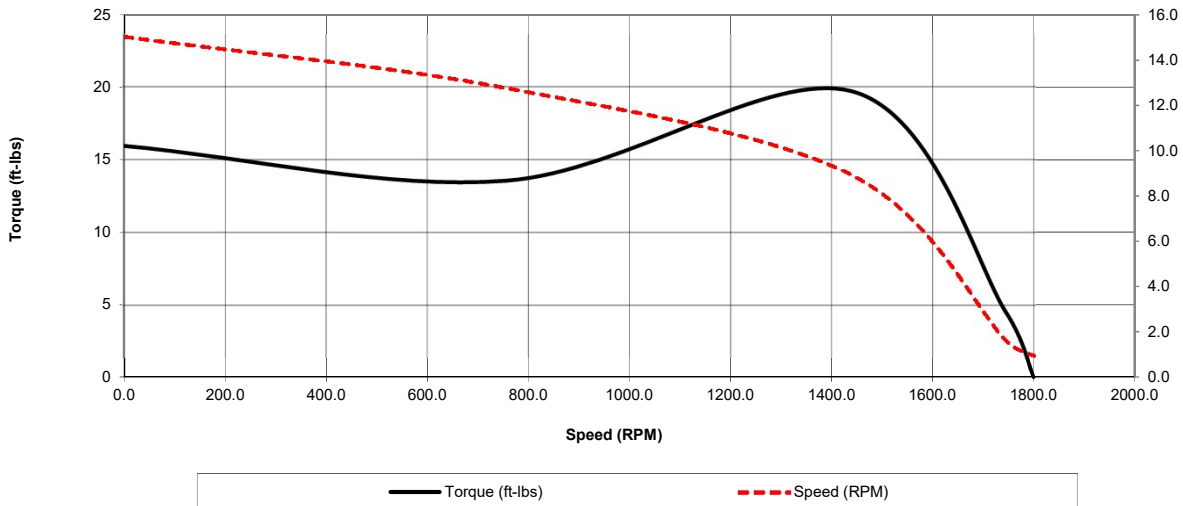

Motor Torque Capability vs RPM

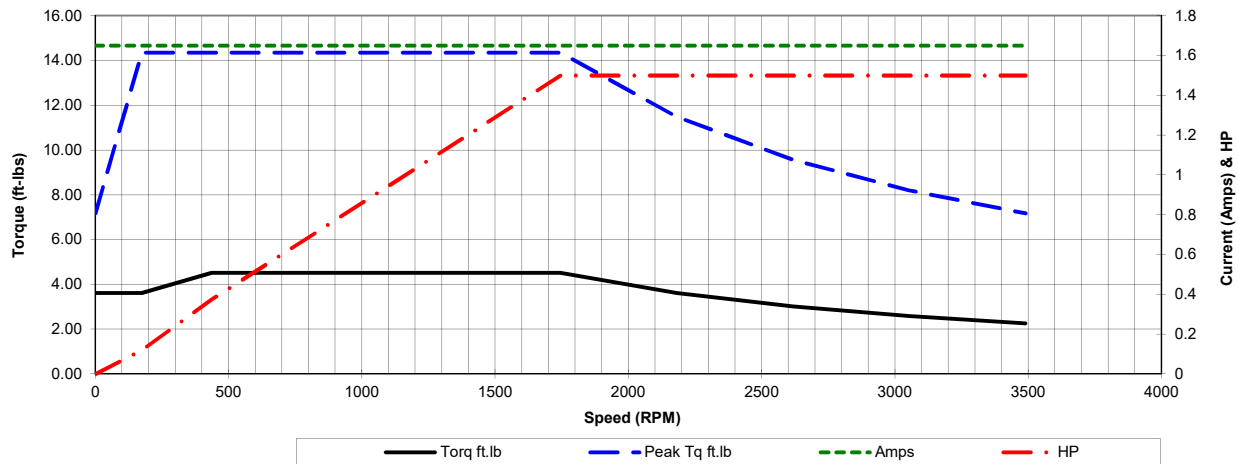



Date: 2020-03-10
 Customer: _____
 Contact: _____
 Submittee: J.C. Lavallée

Catalogue #: **MPRP-154CH**

Meets or exceeds MEPS (Minimum Efficiency Performance Standards), as described by the US Department of Energy in docket 10CFR431 and Natural Resources Canada's Amendment 14										
HP	VAC	RPM	Enclosure	Frame	Frequency	Design	Poles	LR Code Letter	Insulation Class	Temp. Rise °C
1.5	575	1745	TEFC	56HC	60	B	4	L	F	45
Load %	0%	25%	50%	75%	100%	125%	150%			
Amps	0.99	1.05	1.19	1.41	1.65	2.06	2.48			
Torq ft/lbs	0	1.10	2.22	3.36	4.51	5.69	6.88			
RPM	0	1786.25	1772.5	1758.75	1745	1731.25	1717.5			
Eff	0	78.71	82.83	84.48	86.70	84.51	82.09			
PF	0	34.2	57	71	79.0	80.6	83.0			
	Locked Rotor	Pull-Up	Breakdown	Rated Load	Idle	Duty	S. F.	Ambient	Elevation	dBa @ 1M
Speed (RPM)	0	756	1440	1745	1800	Continuous	1.15	40°C	3,300 ft	61
Current (Amps)	15	12.8	8.9	1.65	0.992	VFD Rating: Meets MG1 parts 31.4.4.2				
Torque (ft-lbs)	15.94	13.55	19.68	4.51	0.0	C.T.	10:1	V.T.	20:1	

