

MaxMotion

PERFORMANCE DATA SHEET

Meets or exceeds MEPS, as described by the US DOE in docket 10CFR431 and NRCan's Amendment 14

Catalogue #: **MQS-134FC**

HP	kW	Voltage	S.F. @ 60Hz	EFF.	P.F.	Frame	Design	L.R. Amps
0,33	0,25	230 / 460	1,15	73,4%	0,760	56C	B	6

60 Hz								
FLA							Code	F.L. RPM
208	230	416	460	480	575	600		
1,22	1,1	/	0,55	/	/	/	K	1725

50 Hz								
FLA			S.F. @ 50Hz	Efficiency	Power Factor	Code	F.L. RPM	
190	380	415						
1,3	0,63	/	1,00	71,4%	0,83	K	1440	

Wgt. Lbs	PH	Duty	Insul. Class	Amb.	Elevation	Temp. Rise° C
28	3	Cont.	F	40°C	1000M (3300 Ft)	40

% Efficiency		% Power Factor		Torque		Winding Resist. Ω	Safe Cold Start (Secs)
Full Load:	73,4%	Full Load:	0,76	Full Load Ft/Lbs	1,0		
3/4 Load:	71,6%	3/4 Load:	0,67	Locked Rotor %	288	/	12
1/2 Load:	66,6%	1/2 Load:	0,52	Break Down %	388	/	12

Rotor Inertia Wk2 Lb-Ft2	Max Load Inertia Wk2 Lb-Ft2	Shaft Material	Frame Material	DE Bracket Type	ODE Bracket Type	Enclosure	NEMA Rating	Lead Wire Size
/	/	Stainless Steel				TEFC	IP66	16AWG

Ball Bearings		Grease	Mount Type	Orientation	Paint	Sound Pressure @ 3FT	Sound Power
DE	ODE						
6205	6205	Sealed Bearings	Rigid	Horizontal	-	/	/

Inverter Duty. Motor meets MG1 parts 31.4.4.2	Constant Torque Range	Variable Torque Range	Constant HP RPM
	10:1	20:1	2700

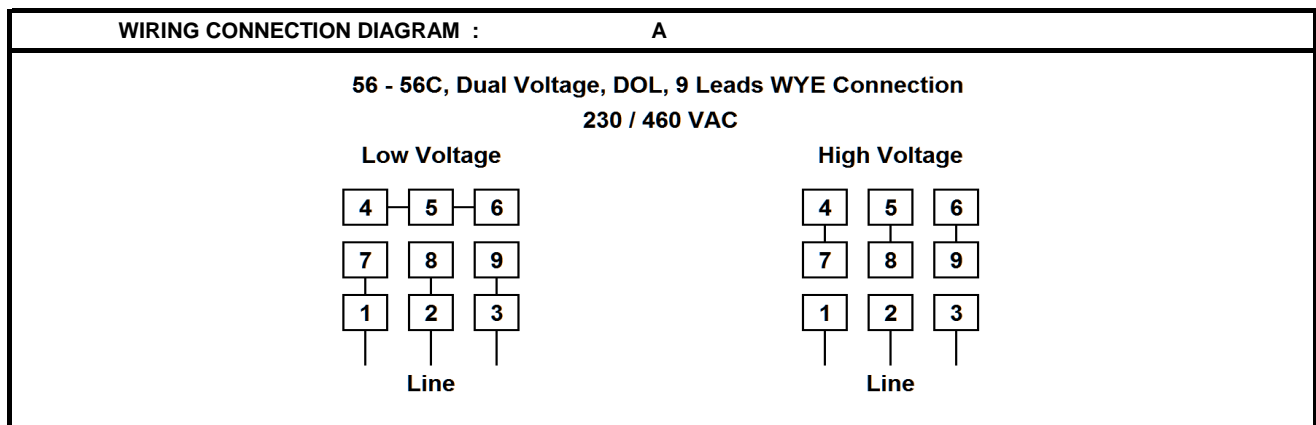

Date: 15/10/2018
 Customer: _____
 Contact: _____
 Submittee: J.C. Lavallée

Catalogue #: **MQS-134FC**

Meets or exceeds MEPS, as described by the US DOE in docket 10CFR431 and NRCAN's Amendment 14

HP	VAC	RPM	Enclosure	Frame	Frequency	Design	Poles	LR Code Letter	Insulation Class	Temp. Rise °C
0,33	460	1725	TEFC	56C	60	B	4	K	F	40

	0Hz	6Hz	15Hz	30Hz	45Hz	60Hz	75Hz	90Hz	105Hz	120Hz
Amps	0,55	0,55	0,55	0,55	0,55	0,55	0,55	0,55	0,55	0,55
RPM	0	172,5	431,25	862,5	1293,75	1725	2156,25	2587,5	3018,75	3450
Torq ft.lb	0,80	0,80	1,00	1,00	1,00	1,00	0,80	0,67	0,57	0,50
Peak Tq ft.lb	1,48	2,95	2,95	2,95	2,95	2,95	2,36	1,97	1,69	1,48
HP	0	0,0	0,1	0,2	0,2	0,3	0,3	0,3	0,3	0,3

	Locked Rotor	Pull-Up	Breakdown	Rated Load	Idle	Duty	S. F.	Ambient	Elevation	dBA @ 1M
Speed (RPM)	0,0	756	1440	1725	1800	Continuous	1,15	40°C	3,300 ft	/
Current (Amps)	6,0	5,1	3,6	0,6	0,4	VFD Rating: Meets MG1 parts 31.4.4.2				
Torque (ft-lbs)	2,9	2,5	3,9	1,0	0,0	C.T.	10:1	V.T.	20:1	

Motor Speed Data

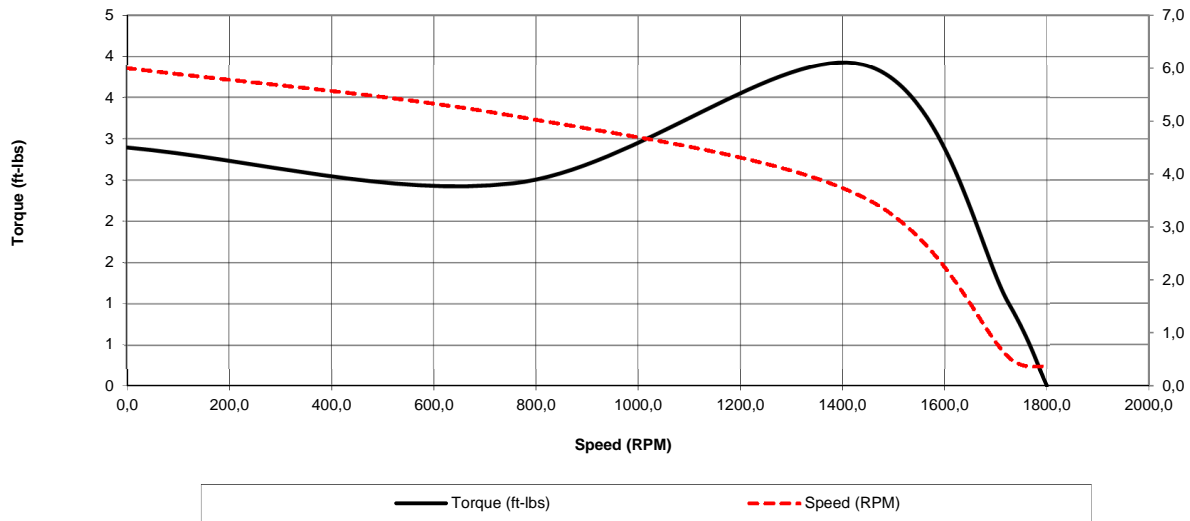

Motor Torque Capability vs RPM

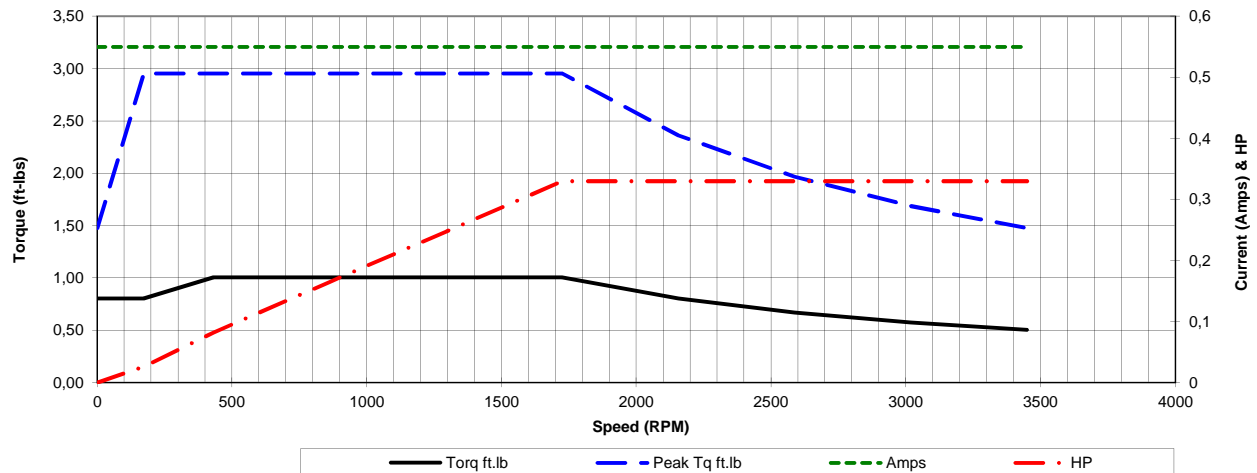

Date: 15/10/2018
 Customer: _____
 Contact: _____
 Submittee: J.C. Lavallée

Catalogue #: **MQS-134FC**

Meets or exceeds MEPS, as described by the US DOE in docket 10CFR431 and NRCan's Amendment 14

HP	VAC	RPM	Enclosure	Frame	Frequency	Design	Poles	LR Code Letter	Insulation Class	Temp. Rise °C
0,33	460	1725	TEFC	56C	60	B	4	K	F	40

Load %	0%	25%	50%	75%	100%	125%	150%
Amps	0,39	0,42	0,45	0,48	0,55	0,69	0,83
Torq ft/lbs	0	0,24	0,49	0,75	1,00	1,27	1,54
RPM	0	1781,25	1762,5	1743,75	1725	1706,25	1687,5
Eff	0	56,55	66,61	71,59	73,40	72,47	70,40
PF	0	32,7	52	66,88	76,0	77,5	79,8

	Locked Rotor	Pull-Up	Breakdown	Rated Load	Idle	Duty	S. F.	Ambient	Elevation	dBa @ 1M
Speed (RPM)	0	756	1440	1725	1800	Continuous	1,15	40°C	3,300 ft	/
Current (Amps)	6	5,1	3,6	0,55	0,385	VFD Rating: Meets MG1 parts 31.4.4.2				
Torque (ft-lbs)	2,89	2,46	3,90	1,00	0,0	C.T.	10:1	V.T.	20:1	

Motor Speed Data

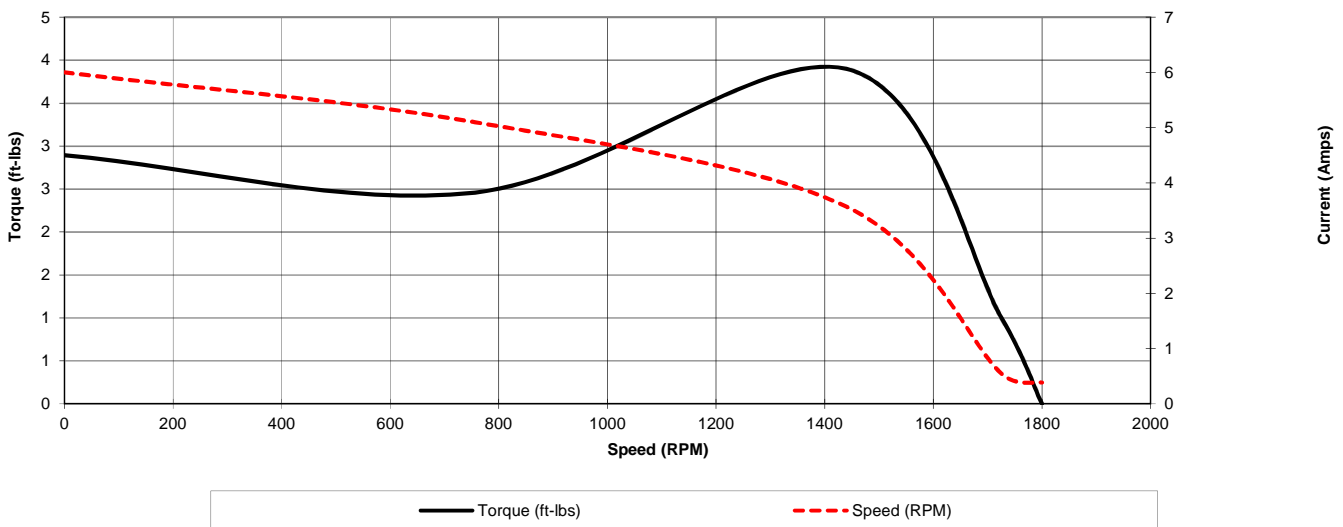

Motor Load Data

