



Date: 2020-03-10

**PERFORMANCE DATA SHEET  
NEMA PREMIUM NR CAN NEMA 12 - 12**

Catalogue #: MQSP-106T

HP	kW	Voltage	S.F. @ 60Hz	EFF.	P.F.	Frame	Design	L.R. Amps
1	0.75	230/460	1.25	82.5%	0.649	143TC	B	15

60 Hz								
FLA							Code	F.L. RPM
208	230	416	460	480	575	600		
3.87	3.5	1.94	1.75	1.68	/	/	K	1165

50 Hz								
FLA			S.F. @ 50Hz	Efficiency	Power Factor	Code	F.L. RPM	
190	380	415						
4.0	2	1.83	1.00	80.0%	0.71	K	965	

Wgt. Lbs	PH	Duty	Insul. Class	Amb.	Elevation	Temp. Rise° C
42	3	Cont.	F	40°C	1000M (3300 Ft)	< 80

% Efficiency		% Power Factor		Torque		Winding Resist. Ω	Safe Cold Start (Secs)
Full Load:	82.5%	Full Load:	0.65	Full Load Ft/Lbs	4.5		
3/4 Load:	82.0%	3/4 Load:	0.60	Locked Rotor %	260		
1/2 Load:	80.0%	1/2 Load:	0.47	Break Down %	330	0	12

Rotor Inertia Wk2 Lb-Ft2	Max Load Inertia Wk2 Lb-Ft2	Shaft Material	Frame Material	DE Bracket Type	ODE Bracket Type	Enclosure	NEMA Rating	Lead Wire Size
0.04	23	Stainless Steel				TEFC	IP66	16AWG

Ball Bearings		Grease	Mount Type	Orientation	Paint	Sound Pressure @ 3FT	Sound Power
DE	ODE						
6205	6205	Sealed Bearings	Rigid	Horizontal	-	55	64

Inverter Duty. Motor meets MG1 parts 31.4.4.2	Constant Torque Range	Variable Torque Range	Constant HP RPM
	10:1	20:1	1800

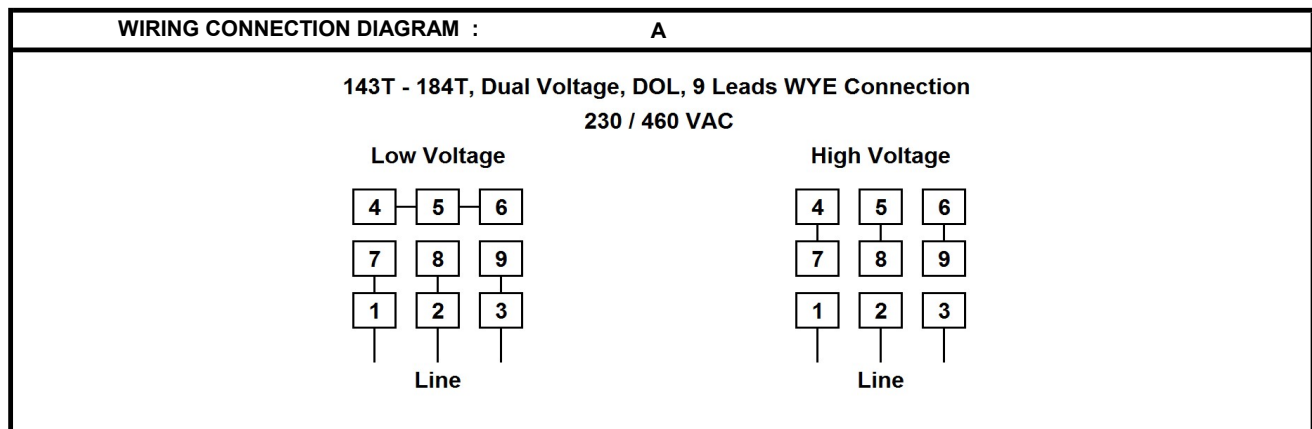

Date: 2020-03-10  
 Customer: \_\_\_\_\_  
 Contact: \_\_\_\_\_  
 Submittee: J.C. Lavallée

Catalogue #: **MQSP-106T**

NEMA PREMIUM NR CAN NEMA 12 - 12										
HP	VAC	RPM	Enclosure	Frame	Frequency	Design	Poles	LR Code Letter	Insulation Class	Temp. Rise °C
1	460	1165	TEFC	143TC	60	B	6	K	F	< 80
	0Hz	6Hz	15Hz	30Hz	45Hz	60Hz	75Hz	90Hz	105Hz	120Hz
Amps	1.75	1.75	1.75	1.75	1.75	1.75	1.75	1.75	1.75	1.75
RPM	0	116.5	291.25	582.5	873.75	1165	1456.25	1747.5	2038.75	2330
Torq ft.lb	3.61	3.61	4.51	4.51	4.51	4.51	3.61	3.01	2.58	2.25
Peak Tq ft.lb	5.97	11.95	11.95	11.95	11.95	11.95	9.56	7.96	6.83	5.97
HP	0	0.1	0.3	0.5	0.8	1.0	1.0	1.0	1.0	1.0
	Locked Rotor	Pull-Up	Breakdown	Rated Load	Idle	Duty	S. F.	Ambient	Elevation	dBA @ 1M
Speed (RPM)	0.0	504	960	1165	1200	Continuous	1.25	40°C	3,300 ft	55
Current (Amps)	15.0	12.8	8.9	1.8	0.8	VFD Rating: Meets MG1 parts 31.4.4.2				
Torque (ft-lbs)	11.7	10.0	14.9	4.5	0.0	C.T.	10:1	V.T.	20:1	

Motor Speed Data

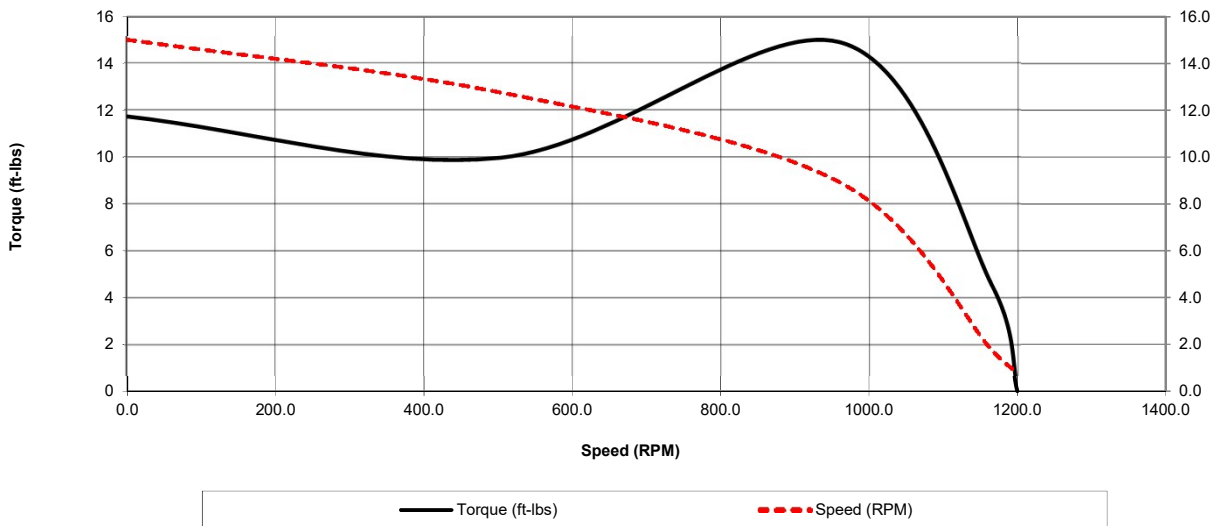

Motor Torque Capability vs RPM

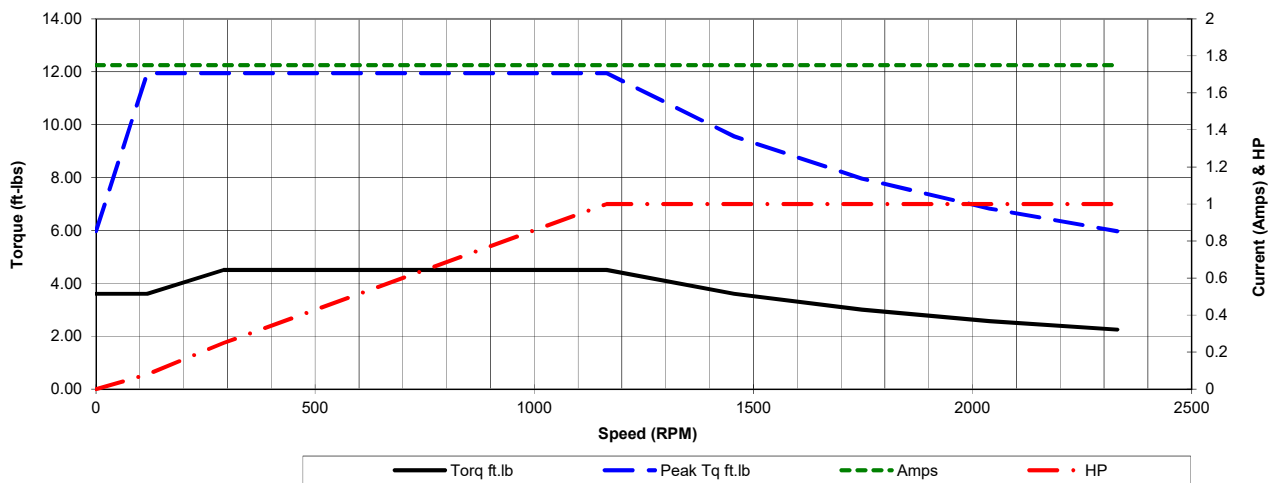

Date: 2020-03-10  
 Customer: \_\_\_\_\_  
 Contact: \_\_\_\_\_  
 Submittee: J.C. Lavallée

Catalogue #: **MQSP-102T**

NEMA PREMIUM NR CAN NEMA 12 - 12										
HP	VAC	RPM	Enclosure	Frame	Frequency	Design	Poles	LR Code Letter	Insulation Class	Temp. Rise °C
1	460	3470	TEFC	143TC	60	B	2	K	F	< 80
Load %	0%	25%	50%	75%	100%	125%	150%			
Amps	0.63	0.65	0.85	1.10	1.40	1.66	1.98			
Torq ft/lbs	0	0.37	0.74	1.12	1.51	1.91	2.31			
RPM	0	3567.5	3535	3502.5	3470	3437.5	3405			
Eff	0	65.52	73.00	76.00	77.00	79.00	77.00			
PF	0	60.0	77	86	90.0	91.8	92.3			
	Locked Rotor	Pull-Up	Breakdown	Rated Load	Idle	Duty	S. F.	Ambient	Elevation	dBA @ 1M
Speed (RPM)	0	1512	2880	3470	3600	Continuous	1.15	40°C	3,300 ft	76
Current (Amps)	15	12.8	8.9	1.4	0.63	VFD Rating: Meets MG1 parts 31.4.4.2				
Torque (ft-lbs)	4.39	3.73	4.99	1.51	0.0	C.T.	10:1	V.T.	20:1	

Motor Speed Data

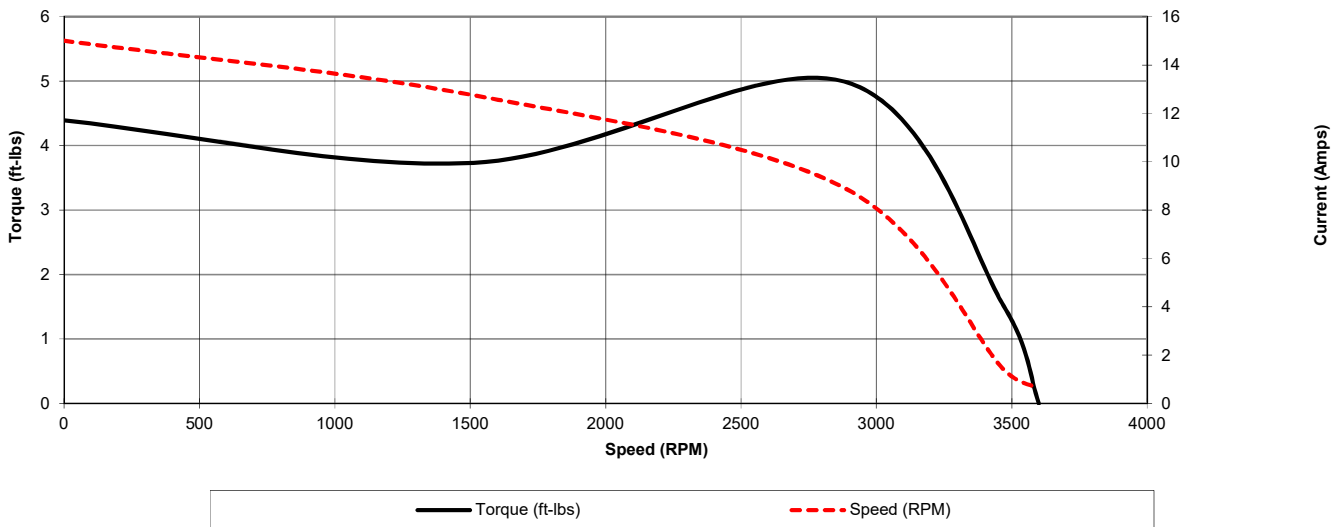

Motor Load Data

