



**PERFORMANCE DATA SHEET  
NEMA PREMIUM NR CAN NEMA 12 - 12**

Catalogue #: **MPSP-106T**

HP	kW	Voltage	S.F. @ 60Hz	EFF.	P.F.	Frame	Design	L.R. Amps
1	0.75	575	1.15	82.5%	0.63	143TC	B	12

FLA							Code	F.L. RPM
208	230	416	460	480	575	600		
/	/	/	/	/	1.44	/	M	1160

FLA			S.F. @ 50Hz	Efficiency	Power Factor	Code	F.L. RPM
190	380	415					
/	/	/	/	/	/	/	/

Wgt. Lbs	PH	Duty	Insul. Class	Amb.	Elevation	Temp. Rise° C
42	3	Cont.	F	40°C	1000M (3300 Ft)	< 80

Full Load:	82.5%	Full Load:	0.63	Full Load Ft/Lbs	4.6	Winding Resist. Ω	Safe Cold Start (Secs)
3/4 Load:	82.0%	3/4 Load:	0.60	Locked Rotor %	260		
1/2 Load:	80.2%	1/2 Load:	0.47	Break Down %	330	0	12

Rotor Inertia Wk2 Lb-Ft2	Max Load Inertia Wk2 Lb-Ft2	Shaft Material	Frame Material	DE Bracket Type	ODE Bracket Type	Enclosure	NEMA Rating	Lead Wire Size
0.04	23	Standard	Rolled Steel	Standard	Standard	TEFC	IP66	16AWG

Ball Bearings		Grease	Mount Type	Orientation	Paint	Sound Pressure @ 3FT	Sound Power
DE	ODE						
6205	6205	Sealed Bearings	Rigid	Horizontal	Stainless Steel	55	64

Inverter Duty. Motor meets MG1 parts 31.4.4.2	Constant Torque Range	Variable Torque Range	Constant HP RPM
		10:1	20:1

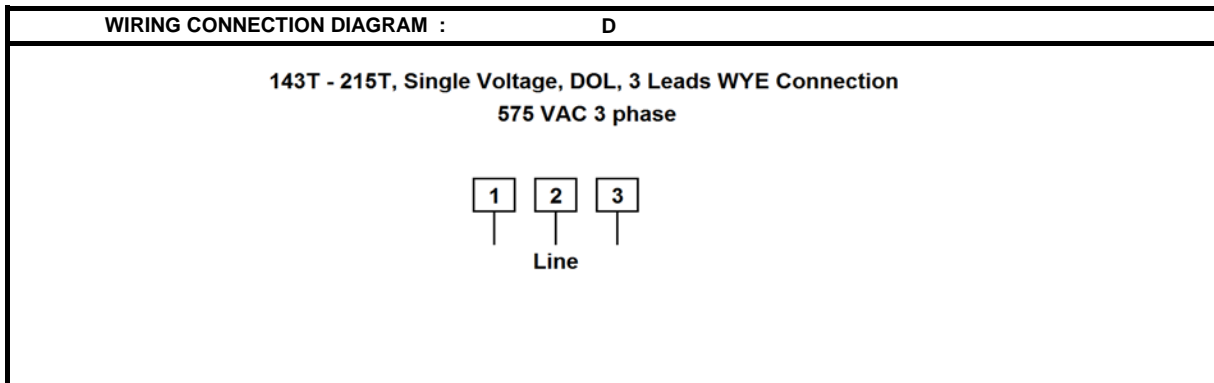



Date: \_\_\_\_\_  
 Customer: \_\_\_\_\_  
 Contact: \_\_\_\_\_  
 Submittee: J.C. Lavallée



Catalogue #: **MPSP-106T**

NEMA PREMIUM NR CAN NEMA 12 - 12										
HP	VAC	RPM	Enclosure	Frame	Frequency	Design	Poles	LR Code Letter	Insulation Class	Temp. Rise °C
1	575	1160	TEFC	143TC	60	B	6	M	F	< 80
Load %	0%	25%	50%	75%	100%	125%	150%			
Amps	0.65	0.67	0.88	1.13	1.44	1.77	2.11			
Torq ft./lbs	0	1.10	2.23	3.37	4.53	5.71	6.91			
RPM	0	1190	1180	1170	1160	1150	1140			
Eff	0	67.37	80.20	82.00	82.50	82.50	82.50			
PF	0	27.09	47	60	63	64.26	64.575			
	Locked Rotor	Pull-Up	Breakdown	Rated Load	Idle	Duty	S. F.	Ambient	Elevation	dBa @ 1M
Speed (RPM)	0	504	960	1160	1200	Continuous	1.15	40°C	3,300 ft	55
Current (Amps)	12	10.2	7.1	1.44	0.648	VFD Rating: Meets MG1 parts 31.4.4.2				
Torque (ft.-lbs)	11.77	10.01	14.94	4.53	0.0	C.T.	10:1	V.T.	20:1	

Motor Speed Data

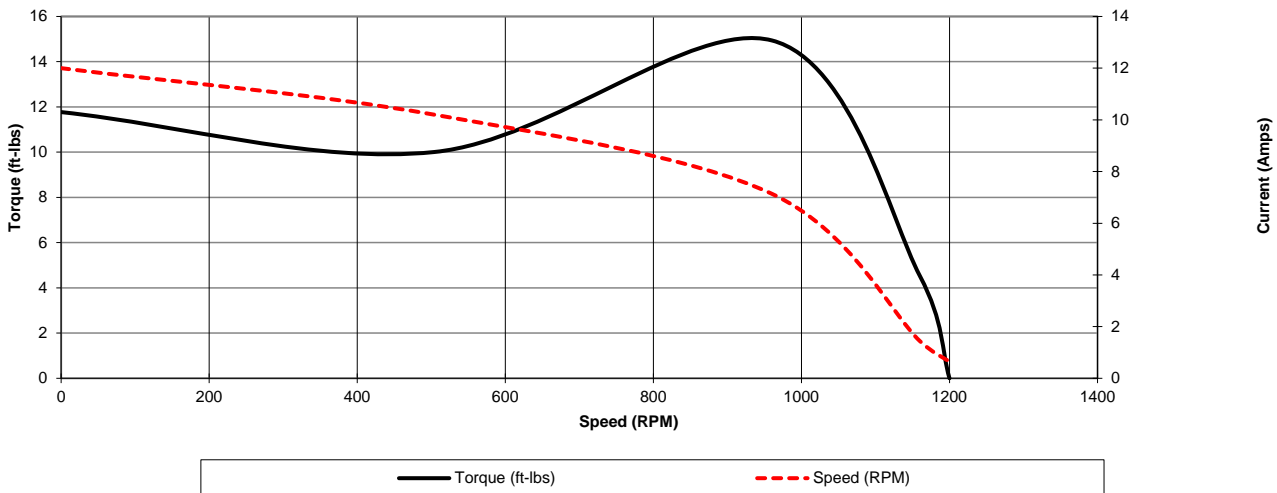

Motor Load Data

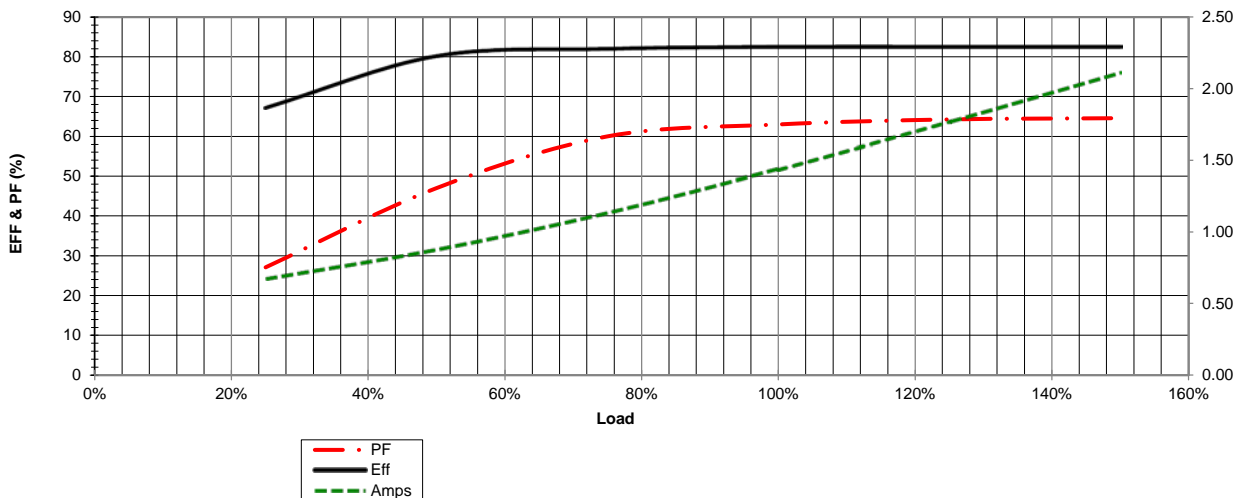



Date: \_\_\_\_\_  
 Customer: \_\_\_\_\_  
 Contact: \_\_\_\_\_  
 Submittee: J.C. Lavallée



Catalogue #: **MPS-106T**

NEMA PREMIUM NR CAN NEMA 12 - 12										
HP	VAC	RPM	Enclosure	Frame	Frequency	Design	Poles	LR Code Letter	Insulation Class	Temp. Rise °C
1	575	1160	TEFC	143TC	60	B	6	M	F	< 80
	0Hz	6Hz	15Hz	30Hz	45Hz	60Hz	75Hz	90Hz	105Hz	120Hz
Amps	1.44	1.44	1.44	1.44	1.44	1.44	1.44	1.44	1.44	1.44
RPM	0	116	290	580	870	1160	1450	1740	2030	2320
Torq ft.lb	3.62	3.62	4.53	4.53	4.53	4.53	3.62	3.02	2.59	2.26
Peak Tq ft.lb	6.00	12.00	12.00	12.00	12.00	12.00	9.60	8.00	6.86	6.00
HP	0	0.1	0.3	0.5	0.8	1.0	1.0	1.0	1.0	1.0
	Locked Rotor	Pull-Up	Breakdown	Rated Load	Idle	Duty	S. F.	Ambient	Elevation	dBA @ 1M
Speed (RPM)	0.0	504	960	1160	1200	Continuous	1.15	40°C	3,300 ft	55
Current (Amps)	12.0	10.2	7.1	1.4	0.6	VFD Rating: Meets MG1 parts 31.4.4.2				
Torque (ft-lbs)	11.8	10.0	14.9	4.5	0.0	C.T.	10:1	V.T.	20:1	

